

Steinway & Sons Model A  
**INSTALLATION  
MANUAL**

## TABLE OF CONTENTS

TABLE OF CONTENTS .....	2
INTRODUCTION TO THE MODEL A .....	3
UNPACKING MODEL A .....	3
SYSTEM PLACEMENT IN THE ROOM .....	10
CONNECTION OF EQUIPMENT .....	11
ROOM CORRECTION INTRODUCTION .....	12
CLEANING THE SPEAKER .....	12
STORING THE SPEAKER .....	12
REPACKING OF MODEL A .....	12
SERVICE INFORMATION .....	12

# INTRODUCTION TO THE MODEL A

## Safety Warnings



### *Physical Handling*

The Model A loudspeakers are very large and heavy. They can be difficult to handle. Follow all instructions for unpacking and installation. Use ergonomically correct body positions. Be careful not to unbalance the large speakers during handling. Steinway Lyngdorf cannot be held responsible for any physical damage which occurs during the installation process.

## UNPACKING MODEL A LOUDSPEAKER

Each crate holds a single Model A loudspeaker mounted on wooden transport panels, which secure the loudspeakers during transportation as well as is of use when lifting the loudspeaker into its final position.

1. Place the crate near its final place in the room. Remove the top.

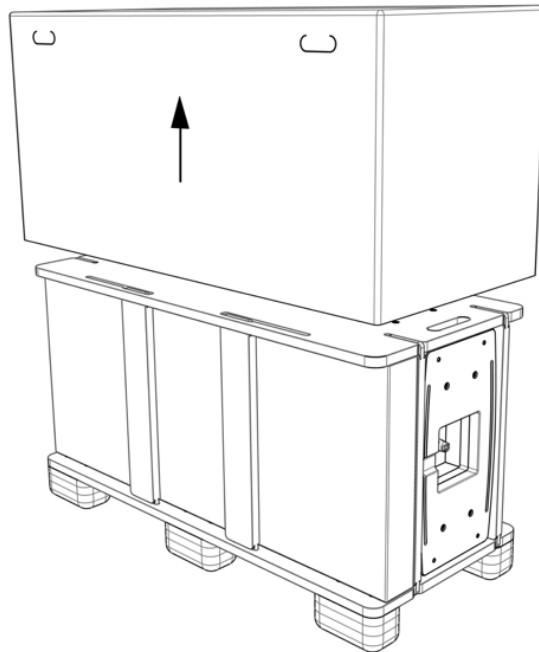

In each crate you will find the following items:

- 1 Model A loudspeaker
- 1 Neutrik speakON cable connector, placed at the underside of the loudspeaker
- 1 carton box containing:
  - 2 Decorative side panels (for left and right)
  - 1 Screwdriver, type Tx30, for removing the wooden transport side panels
  - 1 Spike Kit containing both pointed and rubber pad spikes (4 pcs)

2. Remove the carton box placed at the side. It contains the decorative side panels and accessories.

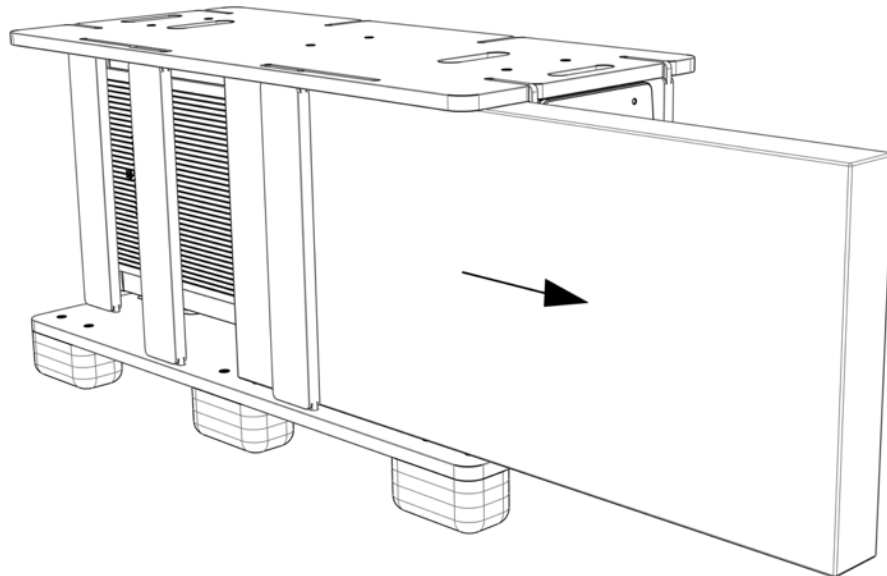

3. Remove the side spacers around the speaker.

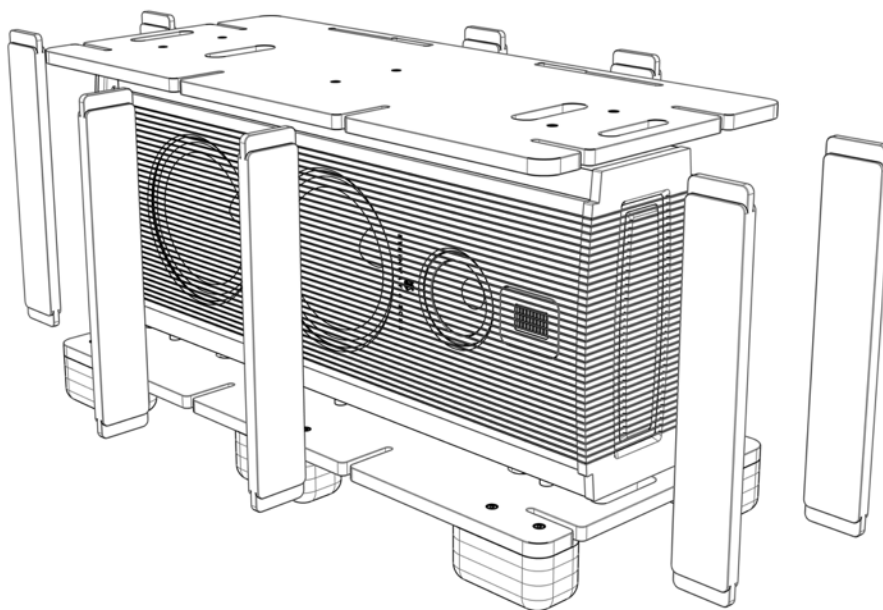

4. Remove the speakON cable connector attached on the underside of the loudspeaker.

5. Fit the speaker cable to the speakON cable connector, according to the Speaker Cable Wiring instruction on a following page of this manual.

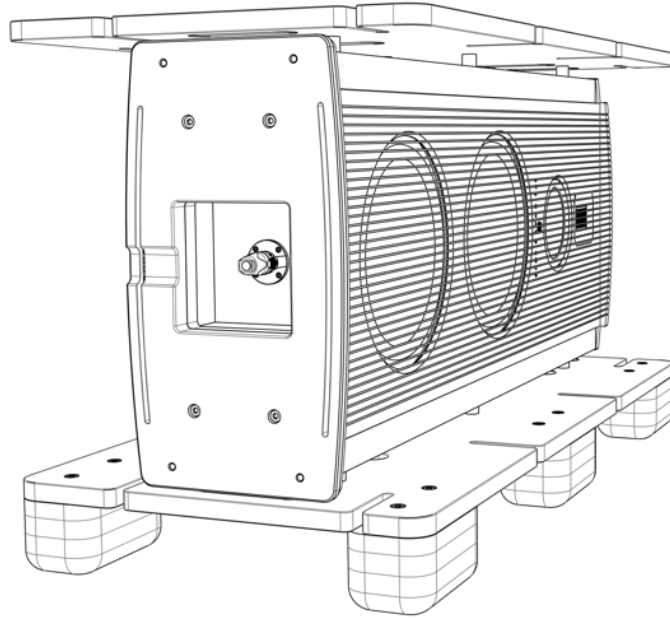

6. Re-connect the speakON cable connector fitted with speaker cable to the speakON chassis connector on the underside of the loudspeaker.

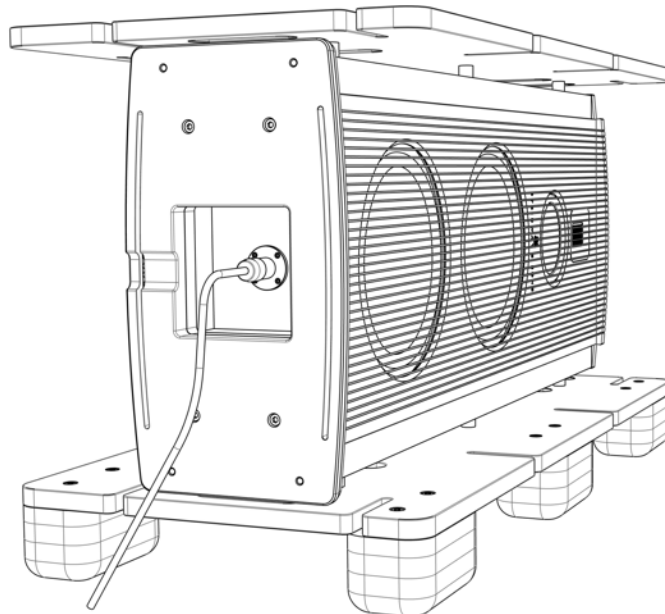

7. Mount the 4 spike feet to the Model A base.

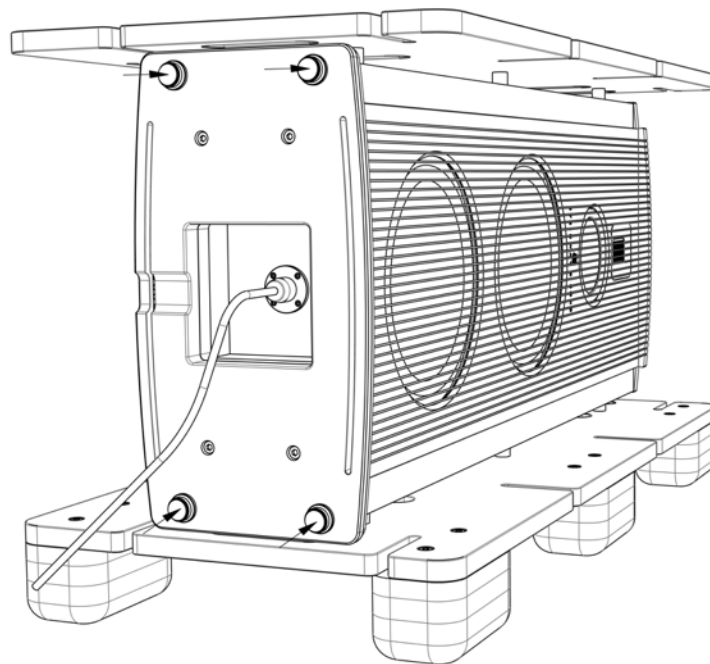

8. Now you can tip the Model A with the pallet unto its spikes. Beware: The speaker is extremely heavy. Make sure the speaker cable runs through the cable opening in the middle of the base.

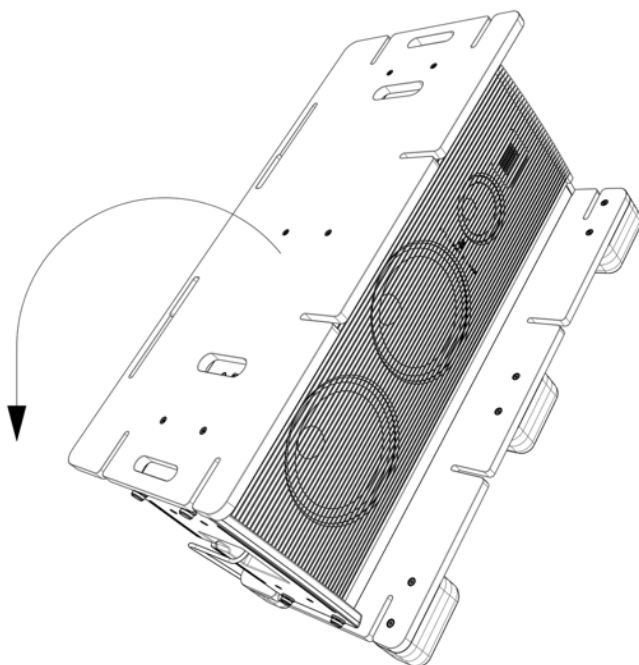

9. On each side, remove 6 screws and take off the wooden pallet and transport side panel.
10. On each side, remove the 6 black transport shock absorbers from the speaker cabinet.

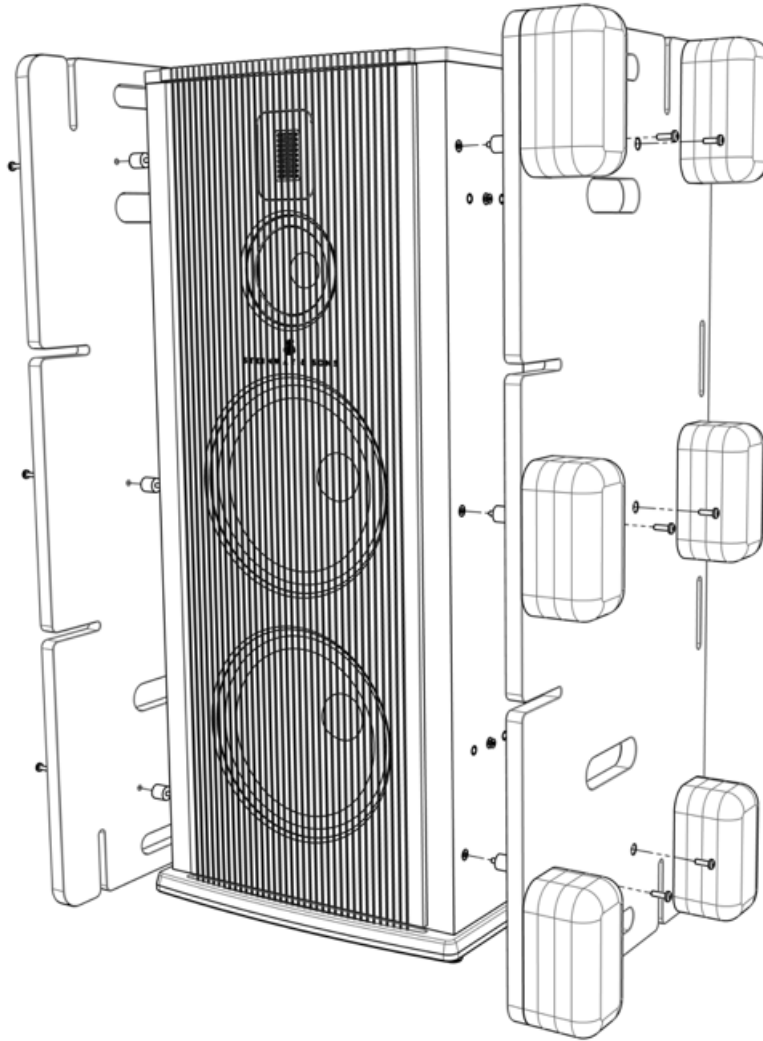

The loudspeaker can now be placed at its final listening position.

## Mounting the Decorative Side Panels

After the loudspeaker has been placed at its final position, the decorative side panels can be attached. The decorative panels will cover left and right sides. Be careful not to scratch the lacquering.

1. Align the panel slightly higher than the loudspeaker. Make sure that the upper and lower screw protruding from the speaker aligns with the upper and lower keyhole inside the panel.

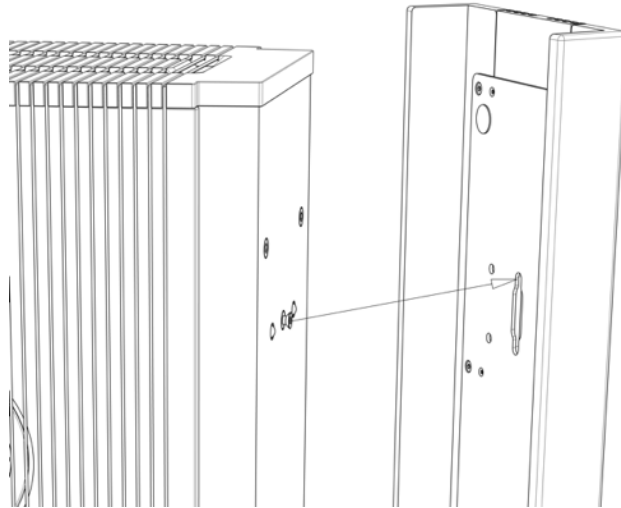

2. Push the whole panel towards the loudspeaker, then press the panel down until it reaches its end stop.

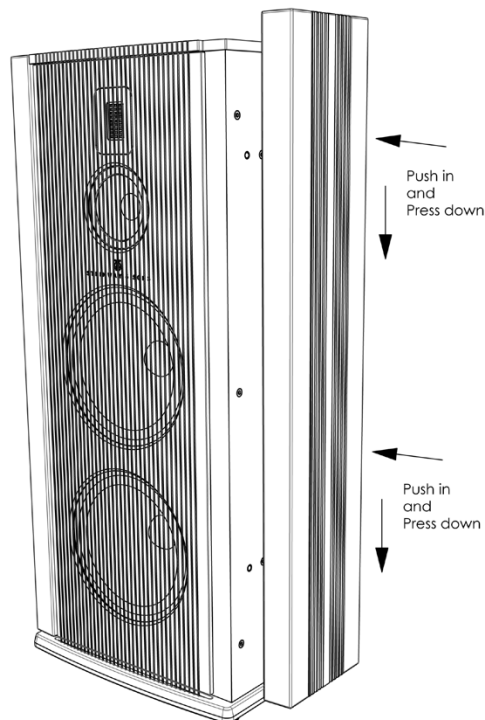



## Removing the Decorative Side Panels

If the loudspeaker needs to be moved again, the decorative side panels should be removed.

1. Press the side panel against the speaker and pull it up. You may carefully use a lever at the speaker base to start lifting the panel up.

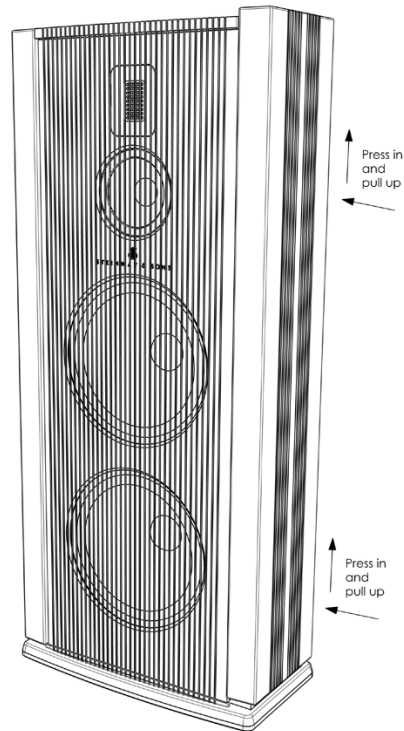

If the loudspeaker needs to be transported to another room or place, the wooden transport panels must be used. Only with the transport panels mounted the speaker can be lifted and carried safely.

1. Remove the decorative side panels as described above.
2. On each side, mount the 6 shock absorbers.
3. Mount the wooden pallet and transport side panel, each with 6 screws.

# LOUDSPEAKER PLACEMENT IN THE ROOM

## Guidelines for Room Placement

Regardless of speaker positioning, the Steinway Lyngdorf RoomPerfect™ calibration will always ensure that the frequency response in the listening position remains the same from both speakers, and the best possible sound performance in the room will be achieved. Always use your ears for positioning the speakers, but for ideal sound performance the following recommendations apply to the Model A:

- The Model A is designed to be placed against the wall. Place the loudspeaker as close as possible to the wall behind it, without touching the wall or the wall's baseboard.
- The setup should be in accordance with the basic stereo triangle (60x60x60 degrees)
- If a symmetrical setup and stereo triangle is impossible and the distance from each speaker to the listening position is different, this can be compensated digitally by adjusting the setup in the Processor.
- Each speaker should ideally be placed at least 1.5 meter or 4.8 feet away from side walls.
- Both speakers should ideally have the same amount of side reflections, i.e. symmetrical positions in the room relative to adjacent walls.
- In most listening positions and speaker placements, no toe-in is required, meaning the loudspeaker should stand in parallel to the wall behind it.
- In listening positions or room layouts where the loudspeakers stand far away from each other, a slight toe-in will improve the high frequency response at the listening position. The wider the setup, the more you need to adjust the toe-in. The tweeters should not be aimed directly at your ears
- After the speaker placement and listening positions have been chosen, run the RoomPerfect™ calibration in your Steinway Lyngdorf Processor.

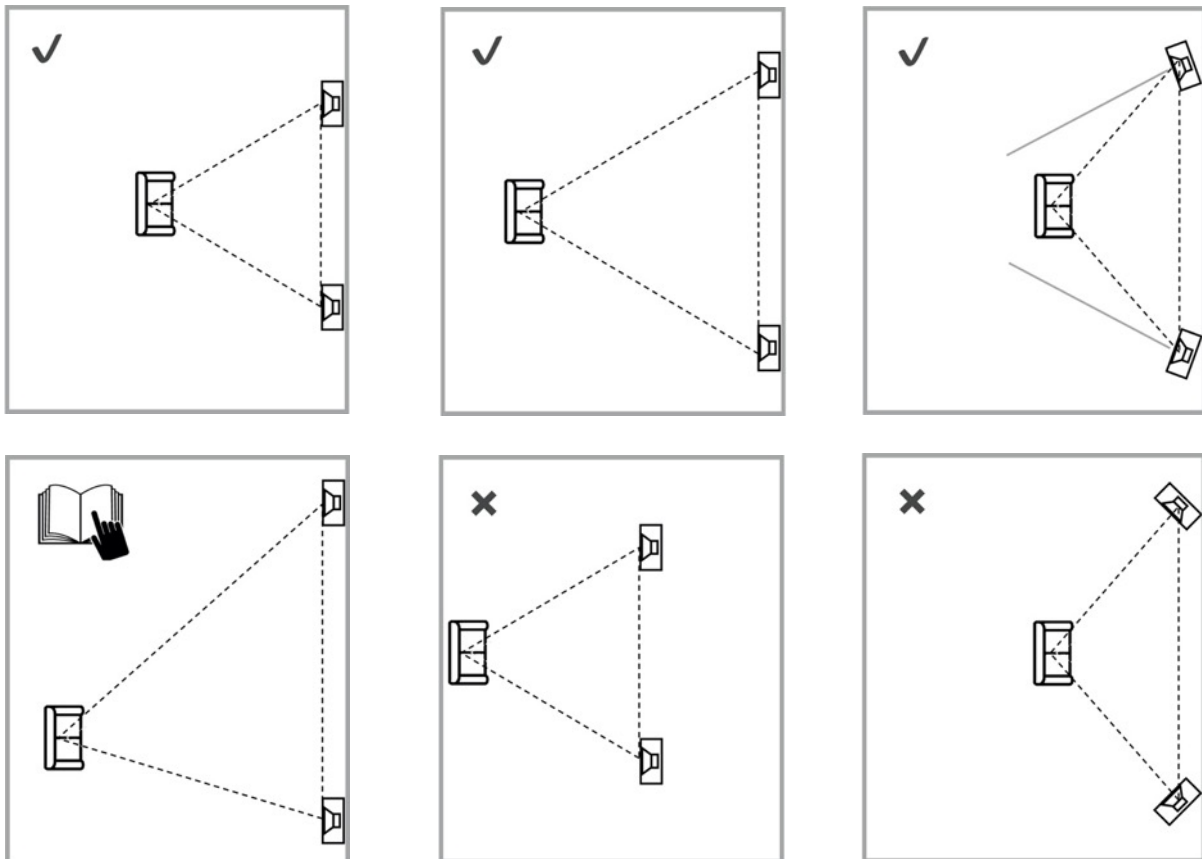

# CONNECTION OF EQUIPMENT

## Speaker Cable Wiring

The Model A is connected to the A1 or A2 amplifiers through speaker wire fitted with speakON connectors.

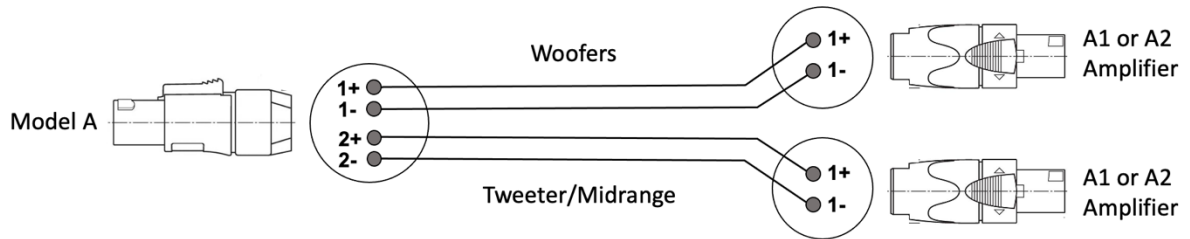

## Amplifier DIP Switchboard Addressing

The speaker will be connected to the A1 or A2 amplifiers, depending on the individual system setup.

The red DIP switchboard on the back of each A1 or A2 amplifier must be set for correct identification of the speaker connected to it.

You will find the actual DIP switch setting in the Wiring Diagram file provided with the Processor.



## ROOM CORRECTION INTRODUCTION

Why do you need room correction? The characteristics of your room affect the sound that reaches your ears. In any system, more than 50% of the sound you hear comes from the contribution of the room, echoes, reflections, absorption, and the like.

Follow the instructions of the Installation Manual of the Processor, but note that during measurements, you can work, talk and move around in the room. But the measurements will last longer depending on the level of background noise.

## CLEANING THE SPEAKER

Polish the system for perfect appearance with a micro fiber cloth. Dust and fingerprints are highly visible on the black piano gloss lacquer. If necessary, moisten your cloth with distilled or demineralized water only.

DO NOT use ordinary furniture polish or cleaning agents as these usually contain wax or silicone that may cause damage to the surfaces.

## STORING THE SPEAKER

The Model A features wooden constructions with high gloss lacquered finish as well as high end electronics. Electronics as well as wooden constructions are vulnerable for sudden changes in temperature as this will cause cracks in the wooden constructions and cause serious degradation of the lifetime of the electronic circuitry.

The products should thus be kept and stored in stable conditions with temperatures between 10° to 25° Celsius and with a relative humidity level between 50% and 55%.

## REPACKING OF MODEL A MUSIC SYSTEM

In case the system components are to be moved to another location repacking into the original shipping crates is necessary, as the weight and vulnerable surfaces are causes of concern.

## SERVICE INFORMATION

To obtain warranty service, you must contact your local representative from Steinway Lyngdorf, or you may email [contact@steinwaylyngdorf.com](mailto:contact@steinwaylyngdorf.com)

In some cases, the Customer Service Department may solve a service problem without the need of repair or any other measures, thereby avoiding further inconvenience or delay. In some cases, it may be necessary to return the equipment to Steinway Lyngdorf or an authorized service provider for repair; therefore, it is recommended that you save your original packing materials. Steinway Lyngdorf will not be responsible for any damage due to unauthorized packing or shipment in non-original packing materials. If return is made in authorized packaging, risks are borne by Steinway Lyngdorf. Additional charges may occur if new packing materials are required for return shipment.

